

PROGRAMMABLE RELAY POWER CENTER

(PRPC)

FEATURES & BENEFITS

- ◆ 8 Programmable power relays
 - ◆ Green LED load indicators
 - ◆ Momentary On/ Off (latching)
 - ◆ On 1/ On 2/ Off two-speed motor control
 - ◆ Timed load, Off/ On
 - ◆ Motor reversing capability
 - ◆ Individually fused loads @ 15 amps max
 - ◆ Fuses with red LED “blown fuse” indicators
- ◆ 7 Programmable low-current outputs (0.5 amps each)
- ◆ 9 Separate digital inputs
- ◆ 2 Analog inputs
- ◆ Optional LIN port for displays
- ◆ Optional CAN port for vehicle communication
- ◆ Overall rating: 75 amps
- ◆ Non-MOSFET design—Generates less heat
- ◆ Familiar technology for easy diagnostics
- ◆ Easy to program using our Graphical User Interface (GUI) software



WHY A PROGRAMMABLE UNIT?

The PRPC communicates with Ford & Chevy CAN, as well as J1939 to provide real-time chassis data for enhanced programmability

Program the PRPC using our Graphical User Interface software with easy to understand, drop-down menus

- ◆ For Safety
 - ◆ Ex.- Only allow power to the bucket if vehicle is in Park **and** Park Brake is set
- ◆ For Convenience
 - ◆ Ex.- Automatically turn on interior lights when transmission is in Park **and** when door is open. Turn lights off when transmission is shifted out **or** Park or door is



An ISO 9001:2008 Registered Manufacturer
www.InterMotive.net 800-969-6080



Rev. B



PROGRAMMABLE RELAY POWER CENTER

(PRPC)

OPERATION

- ◆ Programming of the PRPC is achieved via a Graphical User Interface with easy to understand, drop-down, menus
- ◆ Each of the 8 normally open (NO) mini-relays are controlled individually by the microprocessor
 - ◆ Relays operate in a momentary latch/hold or time out function
 - ◆ Capable of driving individual loads or work in conjunction to operate up to 3 discrete motors in both forward & reverse motions (motor reversing)
- ◆ Other than controlling external loads, the PRPC will not interfere with normal vehicle operation
- ◆ The PRPC will not trigger any PCM or Body Control Module failure modes due to its presence or operation
- ◆ Up to 3 PRPC's can be connected to control up to **45 load's**

APPLICATION

The PRPC can be easily programmed to meet each unique installation using our proprietary Graphical User Interface (GUI). The GUI makes the PRPC perfect for the custom requirements on fire trucks, transit, work truck & ambulance vehicles.

It can be utilized in a variety of applications ranging from a stand-alone power distribution center to an integral part of a vehicle's CAN multiplex system & works on any 12V system.

SPECIFICATIONS

Electrical Specifications

Power Inputs:	+8 to 16 VDC @ 75 amps
Relay Outputs:	+12 VDC, 1 to 15 amps each
Digital Outputs:	High & Low @ 0.05 amps each

Physical Specifications:

Dimensions:	7.25" x 3.5" x 2.5" (LxHxW)
Weight:	0.74lbs.
Operating Temperature:	-40°F to 185°F
Storage Temperature:	-40°F to 212°F

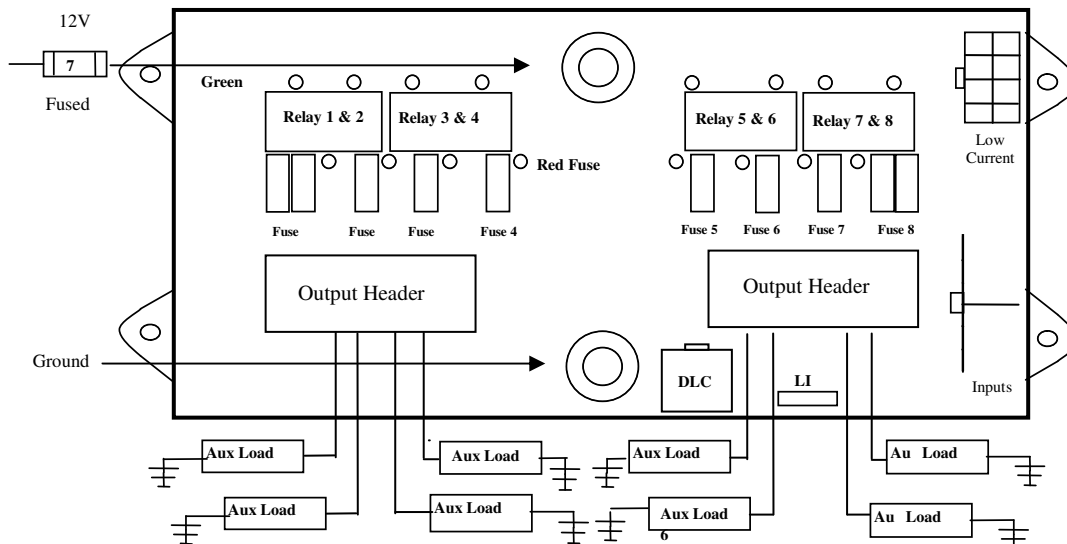

An ISO 9001:2008 Registered Manufacturer
www.InterMotive.net 800-969-6080

