



---

---

## Technical Service Bulletin

**TSB # T2007-01 (Rev 2) – This TSB supersedes TSB # 2007-01 to update the ILIS604G (Chevy Uplander) diagram and circuit.**

**Product:** Intelligent Lift Interlock System

**Model #'s:**

ILIS401-D, 2003 Sprinter, Serial #'s prior to D4011020  
ILIS601-GDB, 2003-2007 Chevy 610 Express Van, Serial #'s prior to GDB6012385  
ILIS602-G, 2000-2005 Chevy Venture, Serial #'s prior to G6021484  
ILIS604-G, 2005-2007 Chevy Uplander, Serial #'s prior to G6041504  
ILIS701-D, International/Freightliner 2002-2007, Serial #'s prior to D7011056  
ILIS801-D, International/Freightliner 2002-2006, Serial #'s prior to D8011181  
ILIS802-D, International/Freightliner 2007, Serial #'s prior to D802075

**Issue:** The shift lock status LED (amber) flashes and the shifter does not lock with the park brake on and/or the lift door open. This will only occur if the vehicle battery voltage drops below 7.5 volts during engine cranking. If you experience this concern, proceed with the following actions. If the concern does not exist, no further action is required.

**Action:** Relocate the ILIS power circuit (Red wire in Pin 1 of the 12-pin ILIS connector) from a hot in "Run & Crank" circuit to a hot in "Run" only circuit.

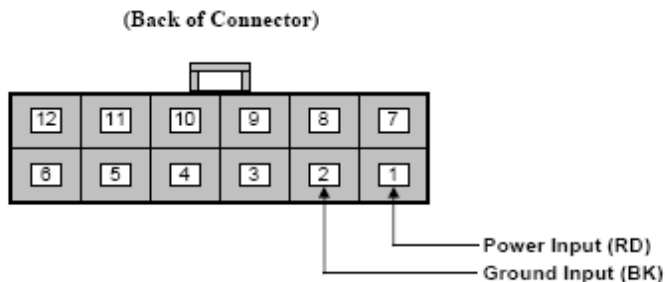

**ILIS401-D, ILIS701-D, ILIS801-D, ILIS802-D**

These are all blunt cut wire harnesses. Use a voltmeter to determine if the red wire is hot in “Run & Crank”. (Pay close attention as there is also a red/white wire in the connector.) If it is, locate a fused power source that is hot in “Run” only and attach the red wire to that source.

**ILIS601-GDB, ILIS602-G, ILIS604-G**

Locate the red wire coming from the ILIS 12-pin connector pin #1. (Pay close attention as there is also a red/white wire in the connector.) Cut this wire about 3-4 inches above the connector. Tape the other cut side of the red wire that runs into the harness and place it back into the split loom. Using solder and heat shrink tubing or tape, extend the red wire to a length of about 2 feet. Connect the newly lengthened red wire to a power source that is hot in “Run” only. Parallel tap into the appropriate circuit by stripping a section of insulation, soldering and using electrical tape. See below for model specific circuits.

**ILIS601-GDB**

Connector C200, Cavity D1, Orange wire - Steering column harness to the I/P harness, at the base of the steering column.

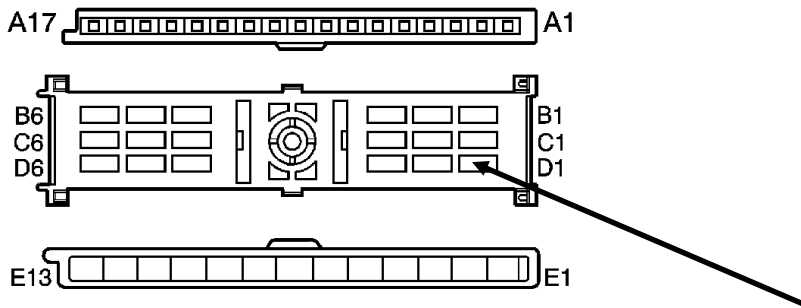

D1	Orange wire	300	Ignition 3 Voltage (Run)
----	-------------	-----	--------------------------

## ILIS602-G

Connector C201, Cavity C6, Orange wire - I/P wiring harness to the steering column wiring harness, mounted to the left side of the steering column near the base.

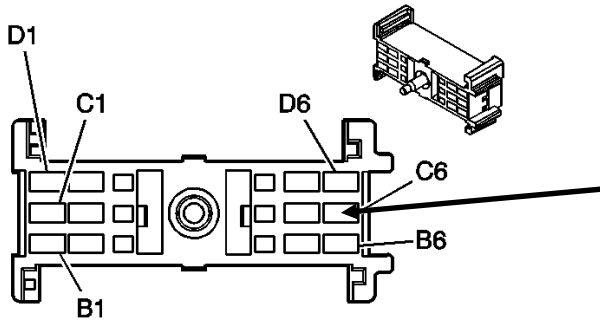

C6	Orange Wire	300	Ignition 3 Voltage (Run)
----	-------------	-----	--------------------------

## ILIS604G

Connector C203, Cavity B9, Brown Wire - Under lower left side of instrument panel, near park brake.

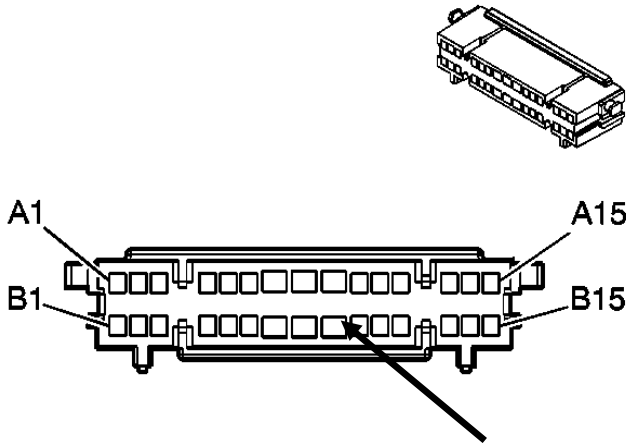

B9	Brown	641	Ignition 3 Voltage (Run)
----	-------	-----	--------------------------

**Technical inquiries** – Bruce Hodge (530) 346-1801