



Eco-Star model ECO601-AT (Transit Applications) 2009-2012 Chevrolet Express/GMC Savana 4.3L, 4.8L, 5.3L, 6.0L, & 6.6L Engines

Introduction

The Eco-Star module ECO601-AT is an automatic engine stop/start system that provides lower vehicle emissions and improved fuel economy by forcing an idling engine to shutoff. The system monitors user inputs, as well as vehicle conditions, to determine when to turn off an idling engine. An anti-idle timer shuts off the engine if safety conditions are met. Engine restarts are triggered automatically by low battery voltages or applying the Service Brake. Refer to the Eco-Star Application Note at www.intermotive.net for additional operation details.

The following default vehicle safety and pre-conditions must be met for ECO601-AT to auto-stop engine idling:

Battery Voltages > 11.8 V	Engine On Request = Not Active
Engine Temp > 170°F Gas / 120°F Diesel	Brake Pedal = Not Pressed
Engine Speed < 1100 RPM	Vehicle Hood = Closed
Outside Air Temp > 32 °F and < 100 °F	Trans Range = Park (Speed = 0)

Note: Most of the above thresholds are customizable and may differ from default values.

When all of the above conditions are met, the ECO601-AT will automatically stop the engine. The engine will be shut off when the idle timer expires or an external discrete wire Ignition Off Request is activated. The default idle timer is set to 15 seconds.

In order to auto-restart the engine, the following conditions must be met:

Vehicle Hood = Closed	Engine Auto-Stopped by ECO601-AT
Trans Range = Park (Speed = 0)	Ignition Key in Run Position

Engine restart is initiated automatically by a low battery voltage, or the application of a user restart input. There are two separate battery sources that can be configured to trigger a battery charge protect restart. By default, the restart voltage is set to 11.8 Volts for the main battery with a re-charge period of at least 60 seconds. The secondary battery input is turned off by default, though it is capable of monitoring up to a 36 Volt input. These and other parameters may be altered to suit your specific needs, using a laptop and InterMotive communication cable. (See ECO-App Note).

Installation Instructions

Disconnect the vehicle's battery before proceeding with the installation.



WARNING
Disconnect the battery to
prevent setting a check engine
light.

It is the installer's responsibility to route and secure all wiring harnesses where they cannot be damaged by sharp objects, mechanical moving parts and high heat sources. Failure to do so could result in damage to the system or vehicle and create possible safety concerns for the operator and passengers.

Remove the lower dash panel below the steering column and find a suitable location to mount the module. Do not mount the module until all wire harnesses are routed and secure. The last step of the installation is to mount the module. It is recommended the module be mounted with two screws, however 2-sided foam tape may also be used. Ensure when routing harnesses that the tilt steering column does not contact them in the full down position. When installing the harnesses, leave several inches of take-out so the module can be removed if necessary.

Data Link Harness Installation

- Locate the vehicle OBDII Data Link Connector. It will be mounted below the lower left dash panel.
- Remove the mounting screws for the OBDII connector. Plug the Red connector from the ECO601-AT Data Link Harness into the vehicle's OBDII connector. Ensure the connection is fully seated and secure with the supplied wire tie.
- Mount the Black pass through connector from the ECO601-AT Data Link Harness in the former location of the vehicle's OBDII connector.
- Secure the ECO601-AT Data Link harness so that it does not hang below the lower dash panel.
- Plug the free end of the Data Link harness into the mating 6-pin connector on the ECO-601-AT module.

Data Link
Harness
plugs in
here



ECO601-AT Harness (12-Pin Connector and 4-Pin Connector)

- Remove the lower steering column trim cover. Locate the Ignition Switch connector (has a Red locking tab) and disconnect it from the switch.



- Note the Pin Numbers on the Ignition Switch connector.

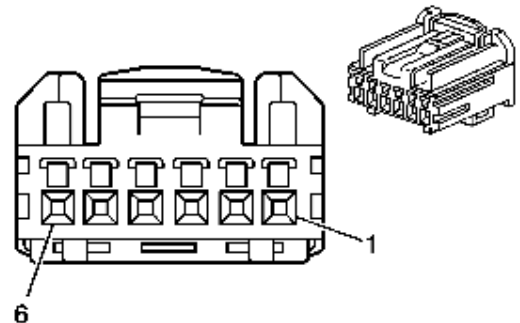

- Locate the Pin #2 Pink wire (there are 2 pink wires on this connector, use the Pink wire on Pin #2), Pin #3 Brown wire, and Pin #6 White wire.
- Find a place on the vehicle Ignition Harness with ample space to install the white 4-pin connectors. (Supplied with ECO601-AT).

Perform only one step at a time, and attach the correct color wire to each white 4-pin connector wire end. These connections must be made by using solder and the supplied heat shrink tubing. Cut the tubing to 1" lengths for this purpose.

- Cut the Ignition Switch Pin #2 Pink wire and attach the ignition switch side to the female 4-pin connector Pin #3 Blue wire.
- Attach the Harness side of the Pin #2 Pink wire to the male 4-pin connector Pin #3 Red wire.
- Cut the Ignition Switch Pin #3 Brown wire and attach the ignition switch side to the female 4-pin connector Pin #2 Orange wire.
- Attach the Harness side of the #3 Brown wire to the male 4-pin connector Pin #2 Brown wire.
- Cut the Ignition Switch Pin #6 White wire and attach the ignition switch side to the female 4-pin connector Pin #1 Gray wire.
- Attach the Harness side of the #6 White wire to the male 4-pin connector Pin #1 White wire.



ECO601-AT Harness (12-Pin Connector and 4-Pin Connector)

- Plug the ECO601-AT 12 Pin connector to mating 12 pin connector on the ECO601-AT module.
- Plug the ECO601-AT 4 Pin connector to mating 4 pin connector on the ECO601-AT module.

I/O Features and Descriptions: (Solder and heat shrink all connections.)

Hood Open Disable Switch

Pin #3 of the module's 4 pin connector is the Hood Open Disable input. A ground signal prevents auto restart when the hood is open. As an important safety feature, this connection must be made to prevent auto restarting when someone is working under the hood area. Extend the Brown Hood Open Disable wire through the firewall into the engine compartment. (Solder and heat shrink all connections). Attach the Hood Open Disable wire to an installer supplied hood switch which grounds this signal when the hood is open. A low current switch with gold contacts is recommended.

Engine/Ignition Off Request Input

Pin #2 (White wire) of the module's 12 Pin Connector is an Engine/Ignition Off Request input to the module which can be used as a remote engine shut down request. As long as this input is active (grounded), ignition switch power will remain off. This mode reduces the draw on the battery to a minimum, allowing the greatest amount of time between low battery restarts. **This switch input must provide a ground when engine off is desired.** (Solder and heat shrink all connections).

Multiple engine shutdown triggers may be used by wiring multiple switches in parallel. Note that it may not be possible to wire existing OEM switches (i.e. door switches) in parallel without affecting other systems. Install additional separate switches if necessary.

I/O Features and Descriptions (cont):

Request Engine On Input

Pin #5 (Green wire) of the module's 12 Pin Connector is the Engine Start Request input. **This switch input must provide a ground when restart is desired.** (Solder and heat shrink all connections). This input also acts as a Shutdown Inhibit. As long as it is active (grounded), the Anti-Idle shutdown timer and the Request Engine/Ignition Off inputs will not turn the vehicle off. A thermistor may be attached to the Engine On input if a temperature activated auto-restart is desired. (Instructions for this option can be found in the Eco-Star App Notes found at www.Intermotive.net).

Security Input

Pin #1 of the module's 4 Pin Connector is an optional security input. When this input is grounded by a switch, the engine will automatically shut off if the Transmission is shifted out of Park. A hidden keyed switch could be used for added security. Crimp one of the provided Molex pins onto an installer supplied wire and insert into cavity 5 of the 12 pin Molex header. Connect free end of wire to installer provided switch.

Battery Input (Up to 36 Volt)

Pin #4 (Gray wire) of the module's 12 Pin Connector is an auxiliary battery voltage monitor input. It measures the analog battery input and can trigger a low battery restart when this input fails below a user defined level. By default, this feature is disabled at the factory, but can be enabled via a laptop connection. Contact InterMotive for details. A spare Molex pin is provided in the kit to allow the use of this input.

Restart Beeper

Pin #3 Orange wire of the module's 12 Pin Connector drives a warning beeper that will sound for 2 seconds prior to a low battery restart. Find a suitable location for mounting the warning beeper so that it is audible to the driver. Some vehicles have a vertical bracket under the center of the dash which works well as a mounting bracket. Connect lead to Red post of beeper, and the Black lead to the negative post. The Black lead eyelet must be grounded in order for the beeper to function. The bezel on the beeper can be rotated to control volume.

I/O Features and Descriptions (cont):

Hot in Run / Start Output

ECO601-AT shuts down the vehicle's engine by simulating a "key off" condition. All electrical loads that are powered from the hot in Run/Start circuit will momentarily lose power when the engine is turned off. This may not be desirable for all loads and can be avoided in 1 of 2 ways. The first is to re-wire any loads that you don't want to lose power to the Run/Acc circuit. The second is by wiring an external relay to Eco-Star's Hot in Run/Start Signal Pin #9 Yellow wire (1 Amp max, see below). This signal simulates the hot in Run/Start signal with the exception that it will not momentarily drop out when Eco-Star shuts the engine off. Keep in mind that any additional loads will drain the battery faster, resulting in a low voltage restart. Use of LED lights and higher capacity batteries is recommended to maximize engine off time.

The Pin #9 output is capable of driving up to 1 Amp max. The use of a diode clamped relay, such as Digikey part number PB682-ND, is strongly recommended. The use of a relay without diode clamped suppression causes high voltage spikes when the relay coil is deactivated. These voltage spikes may cause damage or intermittent behavior to on-board vehicle control modules. Resistors and other methods of clamping are not as effective and are not recommended.

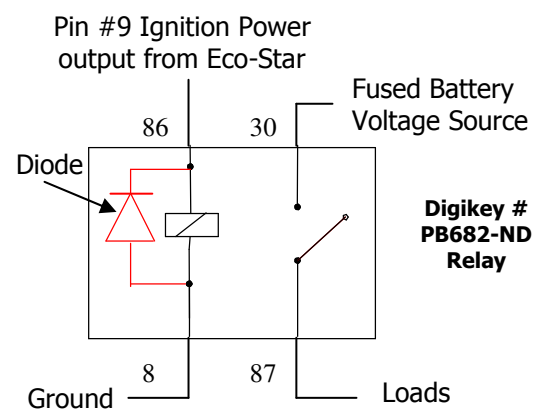

Mounting Location

Ensure all the harnesses are properly connected and routed, and are not hanging below the dash area. Mount the module as described on page one. Verify the module is in an area away from any external heat sources (engine heat, heater ducts, etc.), and mount it with two screws or double sided tape.

Reconnect the vehicle battery

Post Installation Operational Test

Setting module into Installation Test Mode

The installation test mode can be entered by applying a ground to the silver pad on the module labeled "TEST". When test mode activates, the status LED will start blinking; the ECO601-AT now functions without monitoring the following pre-conditions: Engine Temp, RPM, Battery Voltage, or Ambient Air Temp. This allows for easier testing for the installer.

There are still several conditions that will prevent ECO601-AT from auto-shutdown in test mode: Trans Range Not in Park, Brake Pedal Applied, Hood input grounded (Ground = Open), Vehicle Speed not 0, or Engine On/Auto-Stop Inhibit Input is grounded.

Test 1. With engine running, transmission in Park, hood closed, activate the Ignition Off Request switch input. Engine will shut off.

Test 2. Release the Ignition Off Request. Ignition power will be restored once the input is released, loads that are powered with key in Run will be restored.

Test 3. Activate the Engine Start Request. The Engine will automatically restart.

Test 4. Release the Engine Start Request and wait 15 seconds for the Idle Timer to shut the engine off. Note: Applying the brake pedal will prevent the timer from counting down and shutting off the engine.

Test 5. Repeat test 3 with hood open. As a safety feature, the ECO601-AT **should NOT auto restart or stop the engine when the hood is open.** If the ECO601-AT auto restarts or stops engine with hood open, check hood switch wiring.

Do not put vehicle in service unless open hood disables Eco-Star from auto restarting engine.

NOTE: Manually starting the engine with the ignition key after the ECO601-AT has shut the engine off will put the system in Override Mode. ECO601-AT will not shut off the engine for 15 seconds in Override Mode.

IMPORTANT:

If the system fails any of the above tests, check the related wiring. If you cannot discover the fault, call InterMotive tech support. Do NOT release vehicle for service unless it has passed ALL of the above tests.

Eco-Star model ECO601-AT (Transit)
Operating Instructions (to be left in vehicle)
2009-2012 Chevrolet Express/GMC Savana
4.3L, 4.8L, 5.3L, 6.0L, & 6.6L Engines
Contact InterMotive for additional vehicle applications.

- The ECO601-AT module provides enhanced fuel economy and lower vehicle emissions to customers by limiting engine idle time. Vehicle fuel economy is improved by automatically shutting off the vehicle's engine to prevent unnecessary idling. Restarts can be automatically triggered by low battery voltage or user requests.
- The Engine/Ignition Off trigger is a remote switch that when activated turns the engine off by switching off ignition power. The ignition remains off until the vehicle is auto-restarted or the Ignition Off input is removed. This feature reduces the demand on the batteries to a minimum, thereby delaying a low battery restart as long as possible.
- The Engine will also be auto-stopped when the idle time exceeds the time out period. The default timeout period is 15 seconds of idling in Park. After that period elapses, the engine is automatically turned off. The brake pedal and the Engine On/Auto-Stop Inhibit requests will reset the idle timer.
- The Engine On input is a remote switch that when activated will auto-restart the vehicle after an auto-stop has occurred. Activating the Engine On Input while the vehicle is running will prevent any auto-stops from occurring.
- Once the vehicle has been auto-stopped, ECO601-AT starts monitoring the main battery voltage in addition to a secondary battery input. If either fall below a minimum voltage, the module will sound the alarm for 2 seconds and auto-restart the engine to recharge the batteries. The default restart value is 11.8 Volts for the main battery with no secondary battery input. Once the main battery charges above 13.5 Volts, a recharge timer of 60 seconds begins that will turn off the engine again.
- If the security feature is active, the engine will turn off if the transmission is moved out of the Park position. This can prevent theft and/or unauthorized driving.

Default requirements for auto engine shut off:

Engine temperature greater than 170°F (gas) or 120°F (diesel), Battery voltage greater than 11.8 Volts, Transmission in Park (vehicle not moving), Hood Closed, Engine RPM less than 1100, ambient Air Temp between 32°F and 100°F, and Brake Pedal not applied.

Note: The module will not respond to any Ignition Off Requests for 15 seconds after a manual key restart.

Default requirements for auto engine restart:

Engine must have been auto-stopped, Transmission is in Park with the key in the Run position. Hood must be Closed

If those conditions are met, the engine will restart when the Engine On input is activated or a low battery is detected.

At any point, the ECO601-AT may be removed from the vehicle by unplugging the ECO601-AT harness and plugging the two 4 pin Molex connectors together. This will restore the OEM wiring.

InterMotive Inc.
11395 New Airport Rd. Suite A
Auburn, Ca. 95602

Phone: (530)-823-1048
Fax: (530)-823-1516

www.intermotive.net
products@intermotive.net
ECO601-AT-01-OP

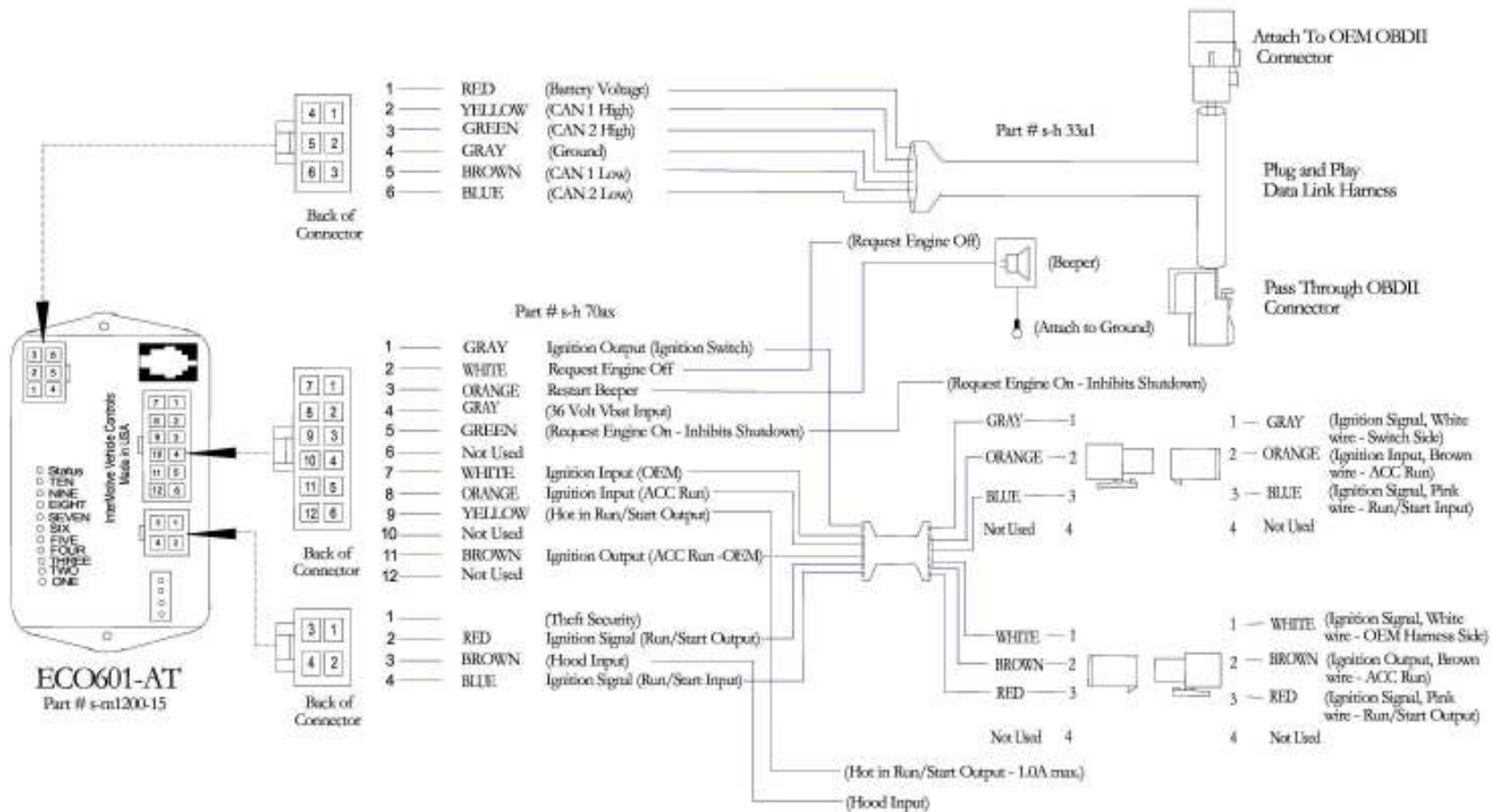

Submit product registration at www.intermotive.net

If the ECO601-AT fails any step in the Post Installation Test, review the installation instructions and check all connections. If necessary, call

InterMotive technical support @ (530) 823-1048.

ECO601-AT-01-CAD