



An ISO 9001:2000 Registered Company

## ILIS Activation Kit (ILIS501-H1) - Installation Instructions

### Ford Econoline – 2005 - 2008

To aid in installation, first gain access to the connection points. Remove the lower dash panel below the steering column. Also gain access to the lift door switch circuit (usually accessible in the front control panel). It is not necessary to cut any Ford wires during the installation of the ILIS Activation Kit.

**LED DISPLAY PANEL (8-Pin Connector)** – Locate a suitable position on the dashboard, within view of the driver for the mounting of the ILIS LED Display Panel. The length of the display harness is 40". This is the maximum distance the display can be from the Gateway<sup>AI</sup> control module. Drill a 1" hole in the dashboard where you wish the center of the display to be. Attach the 8-pin end of the LED harness to the Gateway<sup>AI</sup> control module in the connector labeled "ILIS LED". Run the 10-pin end of the harness under the dash and out through the 1" hole. Attach the 10-pin end of the display harness to the ILIS LED Display Panel. Ensure panel is level, and secure using the supplied screws.

**ILIS "T" HARNESS** - Locate the Ford shift lock solenoid on the steering column and disconnect the black 3-pin connector. Be careful not to break the plastic tab on the connector. Insert the black female 3-pin connector from the ILIS T-harness into the shift lock solenoid. Ensure that it is fully seated into the solenoid. Insert the black male 3-pin connector from the ILIS T-harness into the connector that was originally installed in the shift lock solenoid. **It is imperative that these connectors mate with the tabs on the same side. Use the small wire tie to secure the two tabs together. These connectors must not be allowed to separate.**

**White 4-Pin Connector** – This connector contains the lift power and lift door circuits. The mating harness is to be fabricated by the installer. The recommended mating connector is Molex Part # 0050841040. The recommended mating terminals are Molex Part # 0002081003. The recommended terminal extractor tool is Molex Part # 0011010168. The recommended hand crimp tool is Molex # 0638116800.

- **Lift Activation Circuits** – The lift must be power-side switched. Connect the Yellow wire (Lift In) from pin # 2 of the white 4-pin connector to a fused ignition power source (see lift manufacturers installation instructions). Connect the Orange wire (Lift Out) from pin # 1 of the white 4-pin connector the lift power relay. The lift activation circuit must only activate the lift power relay/solenoid and must not draw more than 8.0 Amps. Make all open-ended wire connections by stripping the insulation, soldering, and taping. **Do not power any other loads (ie: lights, motors, etc.) off this circuit that increase the current draw to greater than 8.0 amps.**
- **Lift Door Circuit** – Locate the lift door switch circuit. Connect the Gray wire from pin # 4 of the white 4-pin connector to this circuit. (Note: the door switch must provide a ground with the door open. A switch that provides power with the door open will not operate correctly).

Finally, plug the White 6-pin connector from the ILIS T-harness (yellow tape) into the "ILIS" connector (colored in yellow) in the Gateway<sup>AI</sup> control module. Ensure the harness is in the correct connector. Installing into the incorrect connector can damage the module. Check for proper lift interlock operation (see Post-Installation Testing sheet). Secure the wiring harnesses and replace the lower dash panel.



---

An ISO 9001:2000 Registered Company

---

## **Lift Enable Switch Installation – Gateway AI with ILIS 501H1**

A lift enable switch may be installed on Gateway AI Modules with the ILIS501H1 option.

1. Attach one side of a latching switch to a wire and crimp the other end of the wire to one of the provided terminals. Only one terminal is needed, one extra is provided. This is a logic level circuit that will draw only milliamps, so a 20 Gauge wire is more than adequate.
2. Insert the crimped terminal into cavity 1 of the supplied 4-pin connector. Cavity 1 will be marked black for easy reference. Attach the other side of the switch to a known good ground point.
3. Insert the 4-pin connector into the header on the Gateway AI module marked “Aux I/O” (white). Do not insert it into the header marked “I/O Port” (green) or damage to the module can occur.

### **The Lift Enable switch operation will then be as follows:**

With the lift switch open (no ground), the lift will be enabled if all other interlock safety conditions are met.

With the lift switch closed (grounded), the lift will be disabled even if all other interlock safety conditions are met.

*The lift can also be enabled/disabled by the InterMotive Merlin Multiplex System, if equipped.*



---

An ISO 9001:2000 Registered Company

---

## ILIS Activation Kit (ILIS501-H1) - Post Installation Testing

### **THE FOLLOWING PROCEDURE MUST BE PERFORMED TO VERIFY PROPER INSTALLATION:**

1. Set Park Brake, place transmission to Park position, and close lift door. Turn ignition to the "Run" position. Do not start vehicle.
2. Verify LED prove-out on LED Status Panel
3. All five (5) upper LEDs should illuminate for approximately two seconds upon initial power on. The lower Icon LED's are backlit and should remain illuminated whenever the Gateway<sup>AI</sup> module is awake.
4. Verify that the Park LED, the Park Brake LED, and the Shift Lock LED remain illuminated.
5. Place foot on service brake and attempt to shift out of Park. Shift lever should not be allowed to shift out of the Park position. If shift lever is allowed to move, check for loose connections at all connection points.
6. Place wheel chocks under the vehicle tires. Release Park Brake. Verify Park Brake LED and the Shift Lock LED on the LED Status panel are no longer illuminated. Remove foot from service brake and attempt to shift out of Park. Shift lever should not be allowed to shift out of the Park position. If shift lever is allowed to move, check for loose connections at all connection points.
7. With Park Brake still released, place foot on service brake and attempt to shift out of park. Shift lever should now be allowed to shift out of Park position. Verify that all upper LEDs are not illuminated with transmission in any other gear. If shift lever is not allowed to move, check for loose connections at all connection points.
8. Place shift lever back to the Park position and verify that the Park LED on the LED Status Panel is illuminated.
9. With Park Brake still released, have an assistant open the lift door(s). Verify that the Lift Door LED and the Shift Lock LED on the LED Status Panel are now illuminated. Place foot on service brake and attempt to shift out of Park. Shift lever should not be allowed to shift out of "Park" position. If shift lever is allowed to move, check for loose connections at all connection points.
10. Set Park Brake. Verify that the Park Brake LED on LED Status Panel is again illuminated. Verify that the Lift Power LED on the LED Status Panel is also now illuminated. All five (5) upper LEDs on the LED Status Panel should now be illuminated. The lift should now be operational. Have assistant verify lift operation.
11. Release Park Brake. Verify that the Park Brake LED and Lift Power LED on the LED Status Panel are not illuminated. Have assistant attempt to operate lift. Lift should not be operational. If lift operates, check for loose connections at all connection points.
12. Set Park Brake. Stow lift and close lift door(s). Turn ignition off. The LEDs will turn off after 5 seconds.
13. If any irregular operational issues persist, contact InterMotive at 530-346-1801 for technical assistance.



**An ISO 9001:2000 Registered Company**

## Gateway<sup>AI</sup> with ILIS Activation Kit (ILIS501-H1) Operating Instructions

The Intelligent Lift Interlock System option (ILIS501-H1) of the Gateway<sup>AI</sup> is a microprocessor driven system for controlling wheelchair lift operation. Lift operation will only be allowed when all of the following conditions are met:

1. The vehicle is in "Park"
2. The parking brake is applied.
3. The vehicle ignition is on.
4. The lift door is open.
5. Lift inhibit is not activated.

The Intelligent Lift Interlock System (ILIS) will not allow the vehicle to be shifted out of park if the lift door is open. As an added feature, it also will not allow the vehicle to be shifted out of park anytime the parking brake is applied. This feature eliminates excessive parking brake wear due to driving with the parking brake applied. The shift lock can also be activated through pin 4 of the I/O port if the proper calibration is installed, or through a command by the InterMotive Merlin Multiplex system, if equipped.

When the vehicle is first started, or if the key is turned to the "Run" position, the five upper LED's on the display panel will illuminate for 2 seconds as a prove out of the LED's. The lower Icon LED's are backlit and should remain illuminated whenever the Gateway<sup>AI</sup> module is awake. After prove out, the operation of the LED panel is as follows:

- Lift Power – Illuminates in green if the lift is enabled. This means that all conditions for lift operation have been met and the lift now has power.
- Park Brake – Illuminates in red when the parking brake is applied.
- Park - Illuminates in red when the vehicle transmission is in the park range.
- Door Open - Illuminates in red when the lift door is open.
- Shift Lock - Illuminates in amber when the lift door is open and/or the parking brake is applied. It can also illuminate from an external command through pin 4 of the I/O port if the proper calibration is installed, or through a command by the InterMotive Merlin Multiplex system, if equipped. If illuminated, the driver will not be allowed to shift out of park.

*Note: If the shift lock LED flashes on and off, this indicates an over current condition in the shift lock circuit. If the center three LED's flash on and off in unison, this indicates an over current condition in the lift power output circuit.*

**All five upper LED's must be illuminated for the lift to operate**

# REVISIONS

DATE: 7/18/07 CHANGE: ECN 2007-0002

## Intelligent Lift Interlock System

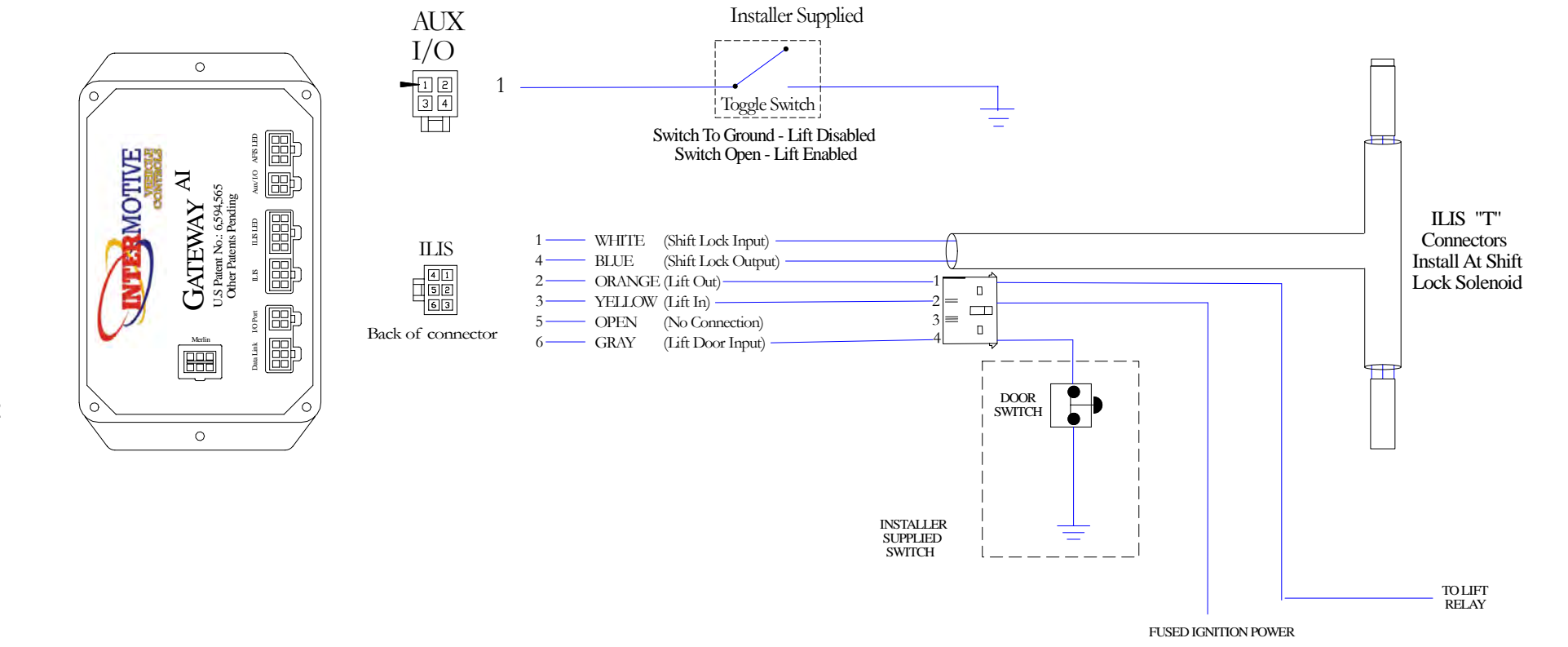
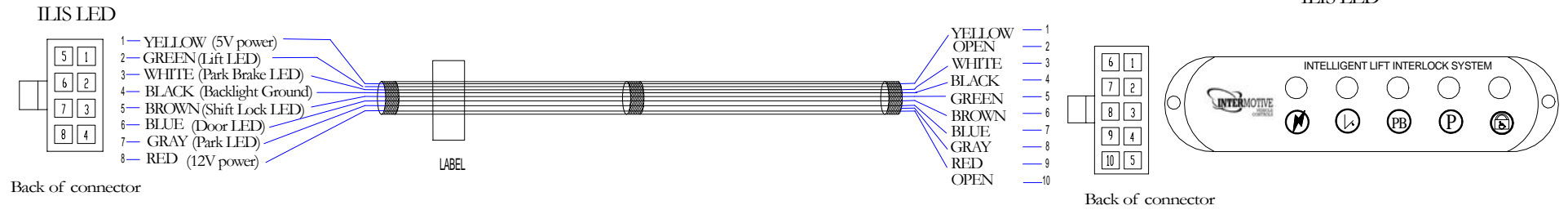

PRODUCT: **GATEWAY AI**

DRAWN BY: BRUCE HODGE  
 DATE DRAWN: 4/18/07  
 PART NO: ILIS501-H1 Rev3  
 CHECK BY: Ed Prokopik  
 DATE CHECKED:

**REVISIONS**

DATE : CHANGE :

AI  
**Gateway**

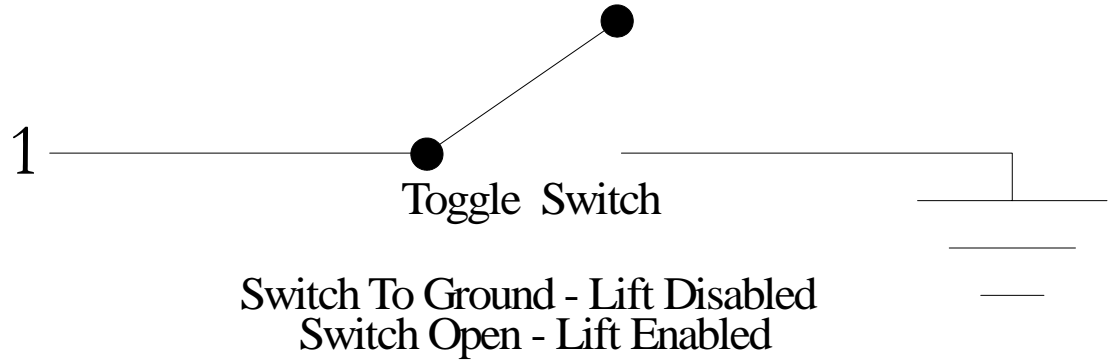
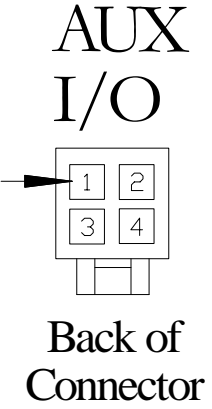
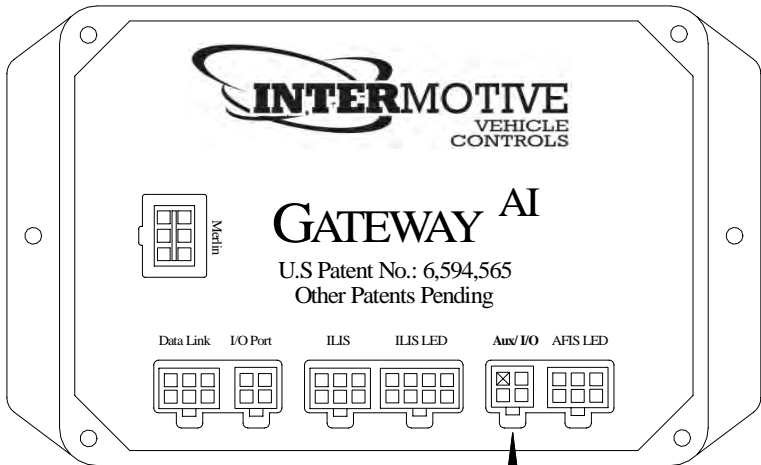

PRODUCT: **Gateway AI ILIS Lift Switch Installation**

DRAWN BY:	SHAWN CONKLIN	PART NO:	GTWY501-A1
DATE DRAWN:	02/01/05	CHECK BY:	Ed Prokopik
		DATE CHECKED:	02/01/05