



An ISO 9001:2000 Registered Company

## Intelligent Lift Interlock System Installation Instructions

**2003-2005 GMT 560 Chassis - Part # ILIS603GD**

**2006-2008 GMT 560 Chassis 8.1L Gas - Part # ILIS605GD**

**2006-2007 GMT 560 Chassis 6.6L Diesel - Part # ILIS605GD**

Ensure you are installing the correct part # for the correct model year (see above). The installation is identical for both part #'s, however the modules are programmed differently.

To aid in installation, first gain access to the connection points. Remove the lower dash panel below the steering column. Also, gain access to the lift power switch and the lift door switch circuits. These are usually accessible in the front control panel. It is not necessary to cut any OEM wires during the installation of the ILIS wire harness.

**LED DISPLAY PANEL (6-Pin Connector)** – Locate a suitable position on the dashboard, within view of the driver for the mounting of the ILIS LED Display Panel. The length of the display harness is 40". This is the maximum distance the display can be from the ILIS control module. Drill a 1" hole in the dashboard where you wish the center of the display to be. Attach the 6-pin end of the LED harness to the ILIS control module. Run the 10-pin end of the harness under the dash and out through the 1" hole. Attach the 10-pin end of the display harness to the ILIS LED Display Panel. Ensure panel is level, and secure using the supplied screws. The two blunt cut wires (red and black) are for optional backlighting of the lower icons. There are three installation options:

1. Do not connect the wires. The display will function properly, but the lower icons will not be backlit.
2. Connect the black wire to ground and the red wire to a 12V ignition switched power source. This will allow the lower icons to be backlit with the ignition in the "on" position.
3. Connect the black wire to ground and the red wire to a 12V headlamp switched power source. This will allow the lower icons to be backlit only when the headlamps are on.

## SHIFT LOCK BRACKET & SOLENOID –



- Loosen both nuts holding steering column to I/P brace.



- Switch OEM shift cable from right-side ball stud to left-side ball stud.



- Slide ILIS bracket and shift lock solenoid assembly between I/P brace and steering column flange.
- Attach shift lock solenoid arm to right-side ball stud.

- Retighten both nuts holding steering column to I/P brace. Verify proper motion of shift lock solenoid by shifting transmission through all ranges (P-R-N-D-2-1). Shift lock solenoid can be adjusted for various lengths by releasing the retaining clip and sliding the solenoid coil along the shaft of the assembly.

**NOTE: THE ILIS SHIFT LOCK SOLENOID WILL NOT ACT AS A BRAKE SHIFT INTERLOCK. TRANSMISSION IS ONLY LOCKED IN PARK IF PARK BRAKE IS SET AND/OR LIFT DOOR IS OPEN.**

**MAIN HARNESS** - Position the main harness such that the 12- pin connector is in position to be installed into the control module. *The connector should not be installed into the module until the main harness is fully installed. All connections must be made with ignition power OFF.* The connection points to be made for the installation of the main harness are listed below.



- **Black 3-Pin Connector** – Remove left kick panel. Locate the OEM Black 3-Pin connector located in kick panel harness assembly. Attach Black 3-pin connector from the ILIS harness to the OEM Black 3-pin connector.
- **Ground Circuit** – Attach the Black, ground circuit eyelet to a known good ground point using a serrated, star washer.

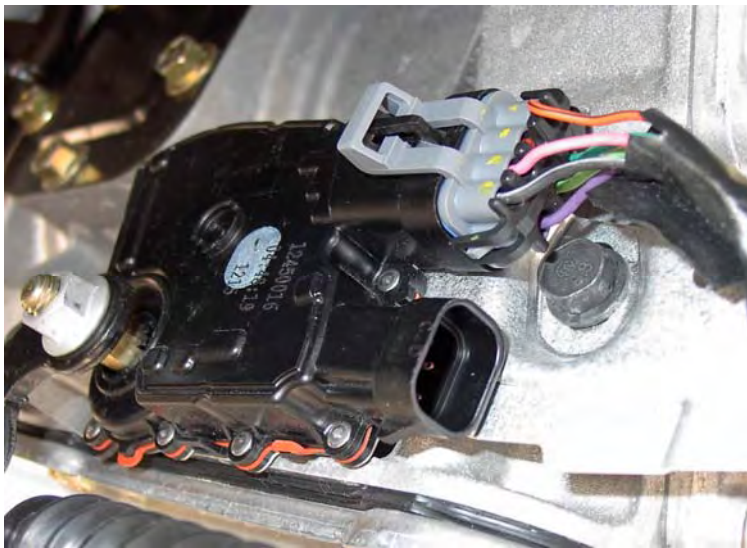

- **Park Circuits** –First determine what type of Transmission Range Sensor the transmission has. (**Two Connector Range Sensor**). Locate the Transmission Range Sensor on the driver's side of the transmission. There are two connectors on this sensor, a 7-pin connector and a 4- pin connector. For this connection, you will use the **two green wires** from the ILIS main harness. These two wires are interchangeable, but they both must be used. Locate and identify the wires in pin cavities B and D in the 4-pin connector. Attach one of the green wires from the ILIS main harness in parallel to the Gray wire in cavity B by stripping the insulation, soldering, and using a

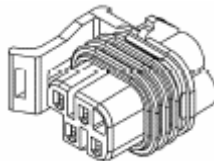
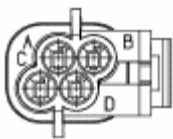

- watertight sealer on the connection anywhere along the length of this wire. **Do not cut the wire.** Attach the other green wire from the ILIS main harness in parallel to the Yellow wire in cavity D by stripping the insulation, soldering, and using a watertight sealer on the connection anywhere along the length of this wire. **Do not cut the wire.**
- **(Single Connector Range Sensor) -** Locate the Transmission Range Sensor on the driver's side of the transmission. There is one 12 pin connector. For this connection, you will use the **two green wires** from the ILIS main harness. These two wires are interchangeable, but they both must be used. Attach one of the green wires from the ILIS main harness in parallel to the Yellow wire in cavity 4 by stripping the insulation, soldering, and using a watertight sealer on the connection anywhere along the length of this wire. **Do not cut the wire.** Attach the other green wire from the ILIS main harness in parallel to the Gray wire in cavity 6 by stripping the insulation, soldering, and using a watertight sealer on the connection anywhere along the length of this wire. **Do not cut the wire.**

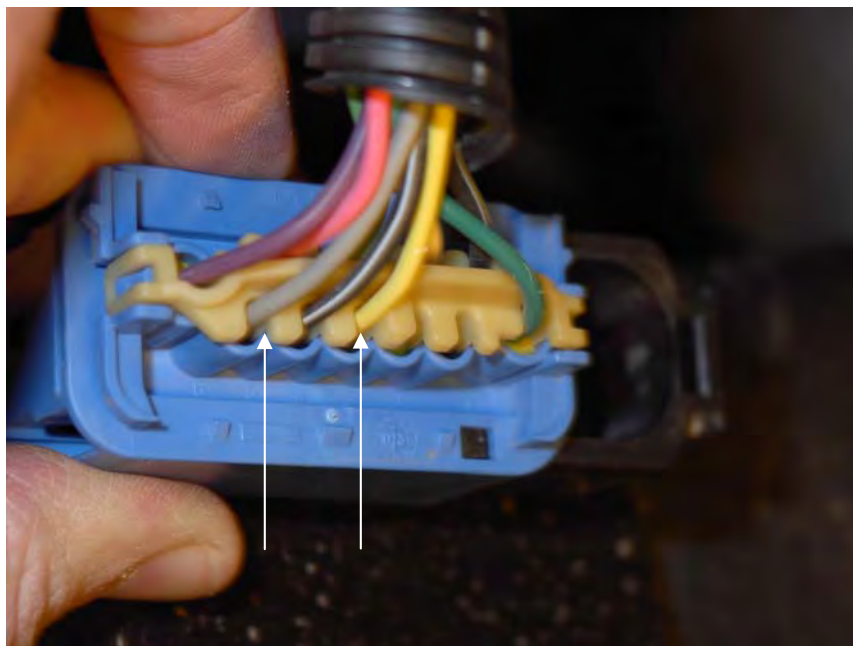

- **(Internal Transmission Range Sensor - 2006 Models) -** Locate the transmission harness connector on the transmission case. It is a 24 pin connector. For this connection, you will use the **two green wires** from the ILIS main harness. These two wires are interchangeable, but they both must be used. Attach one of the green wires from the ILIS main harness in parallel to the Yellow wire in cavity 21 by stripping the insulation, soldering, and using a watertight sealer on the connection anywhere along the length of this wire. **Do not cut the wire.** Attach the other green wire from the ILIS main harness in parallel to the Gray wire in cavity 20 by stripping the insulation, soldering, and using a watertight sealer on the connection anywhere along the length of this wire. **Do not cut the wire.**

- **Shift Lock Circuits** – Attach the Black 2-pin connector from the ILIS harness to the shift lock solenoid.
  
- **Park Brake Circuit** – Disconnect the single-wire OEM connector from the park brake switch. Plug the female side of the connector from the Brown wire from the ILIS main harness to the parking brake. Install the male side of the connector on the Brown wire to the female connector in the OEM harness.
  
- **White 4-Pin Connector** – This connector contains the lift power and lift door circuits. The mating harness is to be fabricated by the installer. The recommended mating connector is Molex Part # 0050841040. The recommended mating terminals are Molex Part # 0002081003. The recommended terminal extractor tool is Molex Part # 0011010168. The recommended hand crimp tool is Molex # 0638116800.
  - **Lift Power Circuit** – Locate the lift power switch. Disconnect the circuit from the switch that goes to the lift relay. **Note: this must be a power switch, not a grounding switch.** Connect this circuit to the Blue/White wire from pin # 1 of the white 4-pin connector. Connect the Yellow wire from pin # 2 of the white 4-pin connector to the power switch. The lift power circuit must only activate the lift power relay/solenoid and must not draw more than 7.0 Amps. **Do not power any other loads (ie: lights, motors, etc.) off this circuit**
  
  - **Lift Door Circuit** – **Note: the door switch must provide a ground with the door open. A switch that provides power with the door open will not operate correctly!** Locate the lift door switch circuit. Connect the Red/White wire from pin # 4 of the white 4-pin connector to this circuit.
  
- **Park Output Circuit** – This is an optional circuit that provides a ground in Park gear only. This circuit is useful if the operator wishes to activate or deactivate an accessory only in Park (ie: power operated front door). Attach the **White** wire from the main harness to the ground side of the accessory. If this option is not desired, cut the wire at the 12-pin connector and discard the wire. **Note: This output can only carry low current loads such as a relay primary coil. Higher loads can cause damage to the control module. The current of the load must first be determined and can not exceed 500 milliamps continuous load. This wire must not be attached directly to power without a load, or damage to the control module will result.**

Finally, snap the 12-pin connector of the main wire harness into the control module. Make sure the connector is fully seated. Secure the control module behind the lower dash panel using 2-sided foam tape, wire ties, or screws.



**An ISO 9001:2000 Registered Company**

## **Post Installation Instructions – ILIS603GD / ILIS605GD**

Upon completion of installation of the Intelligent Lift Interlock System, the following procedure **MUST BE PERFORMED TO VERIFY PROPER INTERLOCK INSTALLATION AND FUNCTION:**

- Set Park Brake, place transmission to Park position, close lift door, and turn Lift Power Switch to the off position. Turn ignition to the “Run” position. Do not start vehicle.
- Verify LED prove-out on LED Status Panel
  - All five (5) LEDs should illuminate for approximately one (1) second upon initial power on.
- Verify that the Park LED, the Park Brake LED, and the Shift Lock LED remain illuminated.
- Place foot on service brake and attempt to shift out of Park. Shift lever should not be allowed to shift out of the Park position. If shift lever is allowed to move, check for loose connections at all connection points.
- Release Park Brake. Verify Park Brake LED and the Shift Lock LED on the LED Status panel are no longer illuminated. Verify that all LEDs are not illuminated with transmission in any other gear. If shift lever is not allowed to move, check for binding of shift linkage.
- With Park Brake still released, have an assistant open the lift door(s). Verify that the Lift Door LED and the Shift Lock LED on the LED Status Panel are now illuminated. Place foot on service brake and attempt to shift out of Park. Shift lever should not be allowed to shift out of “Park” position. If shift lever is allowed to move, check for loose connections at all connection points.
- Set Park Brake. Verify that the Park Brake LED on LED Status Panel is again illuminated. Turn on Lift Power Switch. Verify that the Lift Power LED on the LED Status Panel is now illuminated. All five (5) LEDs on the LED Status Panel should now be illuminated. Have assistant verify lift operation. Lift should now be operational.
- Release Park Brake. Verify that the Park Brake LED and Lift Power LED on the LED Status Panel are not illuminated. Have assistant attempt to operate lift. Lift should not be operational. If lift operates properly, check for loose connections at all connection points.
- If any irregular operational issues persist, contact InterMotive at 530-346-1801 for technical assistance.

# REVISIONS

DATE: 7/18/07 CHANGE: ECN 2007-0002

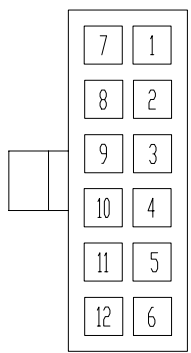

ILIS 603  
12 PIN  
CONNECTOR

- 1 — RED — POWER INPUT - ATTACH TO BLACK 3 PIN CONNECTOR IN KICK PANEL
- 2 — BLACK — GROUND INPUT - ATTACH TO GOOD GROUND POINT
- 3 — BLUE — SHIFT INTERLOCK OUTPUT - ATTACH TO SHIFT-LOCK SOLENOID (BLACK 3 PIN T-HARNESS CONNECTOR)
- 4 — OPEN
- 5 — YELLOW — LIFT POWER INPUT - ATTACH TO OUTPUT SIDE OF LIFT POWER SWITCH
- 6 — BLUE / WHITE — LIFT POWER OUTPUT - ATTACH TO LIFT POWER RELAY
- 7 — GREEN — PARK-B1 INPUT - ATTACH TO TRANSMISSION RANGE SENSOR CIRCUIT
- 8 — GREEN — PARK-B2 INPUT - ATTACH TO TRANSMISSION RANGE SENSOR CIRCUIT
- 9 — OPEN
- 10 — WHITE — OPTIONAL PARK-ONLY OUTPUT (GROUND SIGNAL)
- 11 — BROWN — PARK BRAKE INPUT - ATTACH TO PARK BRAKE SWITCH
- 12 — RED / WHITE — LIFT DOOR INPUT - ATTACH TO LIFT DOOR SWITCH INPUT (GROUND SIGNAL)

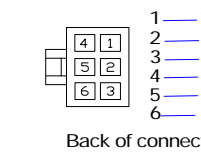
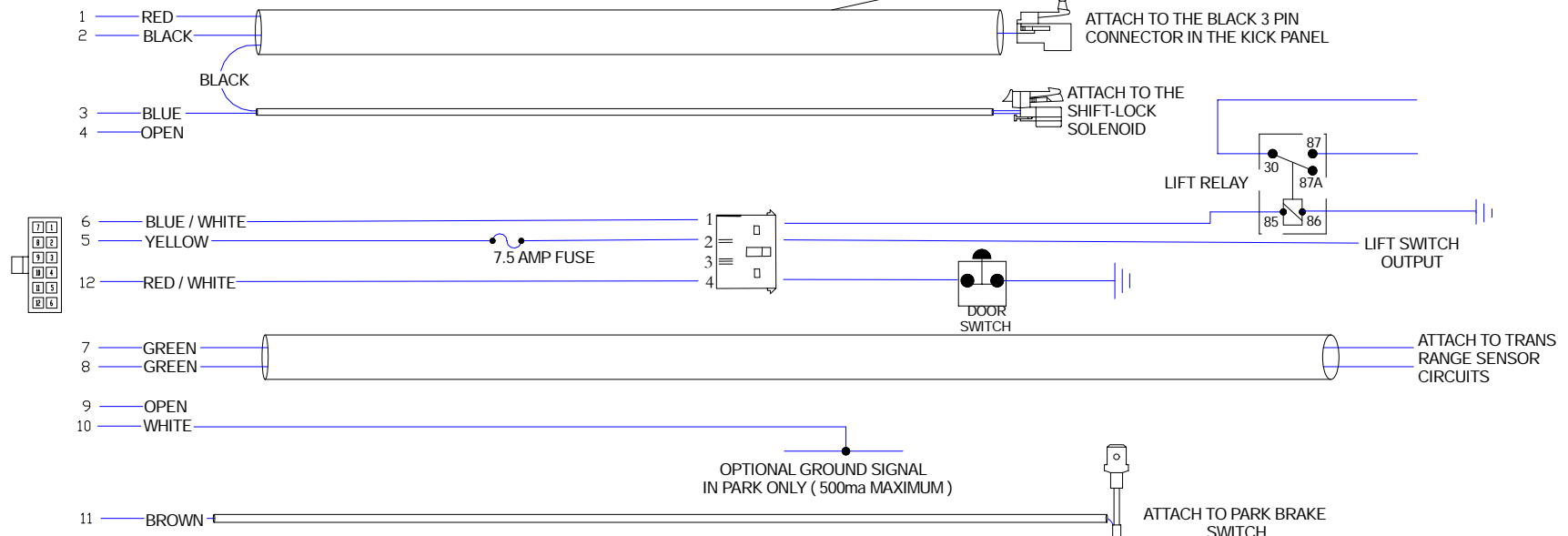
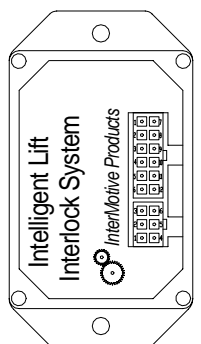

Back of connector

BLACK (ATTACH TO GROUND)  
RED (ATTACH TO 12V POWER) (EITHER IGNITION POWER, OR HEADLAMP CIRCUIT)  
(OPTIONAL FOR BACKLIGHTING OF LOWER ICONS)

- YELLOW — 1
- OPEN — 2
- WHITE — 3
- BLACK — 4
- GREEN — 5
- BROWN — 6
- BLUE — 7
- GRAY — 8
- RED — 9
- OPEN — 10

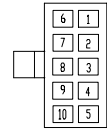

Back of connector

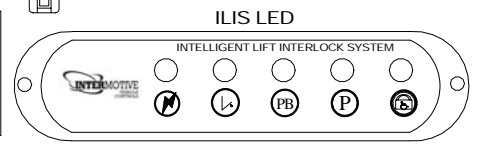

ILIS LED



PRODUCT: **INTELLIGENT LIFT INTERLOCK SYSTEM**

DRAWN BY: SHAWN CONKLIN  
DATE DRAWN: 10/21/05  
CHECK BY: Ed Prokopik  
PART NO: ILIS 603/605 GD  
DATE CHECKED: