



An ISO 9001:2008 Registered Company

# NFPA501-A Seat Belt Monitoring System

## 2011 Ford F250-550 Series Crew Cab 6.2L, 6.7L, 6.8L

### Introduction

The NFPA501-A system acts as both a “translator” for chassis data as well as an input device for seat and seat belt sensors. All data collected either via OBDII (CAN) data stream or discretely from a sensor will be transmitted over a separate, proprietary InterMotive CAN network that adheres to the SAE J-1939 protocol. This will allow various Vehicle Data Recorders (VDR) from multiple manufacturers to simply read the NFPA501-A provided J1939 data without having to make significant changes to their VDR.

The following are the specific chassis data provided by this translator:

- Accelerator Pedal Position - SPN91, PGN 0xF003 (61443)
- Engine RPM - SPN190, PGN 0xF004 (61444)
- Engine Coolant Temperature - SPN110, PGN 0xFEEE (65262)
- Transmission Fluid Temperature - SPN177, PGN 0xFEFE (65272)
- Transmission Range - SPN163, PGN 0xF005 (61445)
- Engine Oil Pressure - SPN100, PGN 0xFEEF (65263)
- ABS State - SPN563, PGN 0xF001 (61441)
- Vehicle Speed - SPN84, PGN 0xFEFE (65265)
- Parking Brake - SPN70, PGN 0xFEFE (65265)
- Service Brake - SPN597, PGN 0xFEFE (65265)
- Key Position - PGN 0xFEFE (65265)
- VIN - SPN237, PGN 0xFEEC (65260)

In addition, seat occupant / belt buckle status, along with optical warning system status are provided on the J1939 data stream for use with a Vehicle Data Recorder. The NFPA501-A acquires chassis data passively except during installation, so it will not interfere with other devices connected to the OBDII connector.



#### WARNING

Disconnect the battery to prevent setting a check engine light.

**Be sure the vehicle's battery is disconnected before proceeding with the installation.**

### Installation Instructions

Remove the lower dash panel below the steering column area and find a suitable location to mount the NFPA501-A module. Do not mount the module until all wire harnesses are routed and secure. (The last step of the installation is to mount the module).



It is the installer's responsibility to route and secure all wiring harnesses where they cannot be damaged by sharp objects, mechanical moving parts and high heat sources. Failure to do so could result in damage to the system or vehicle and create possible safety concerns for the operator and passengers.

InterMotive Inc.  
13395 New Airport Rd. Suite A  
Auburn, Ca. 95602

Phone: (530)-823-1048  
Fax: (530)-823-1516

www.intermotive.net  
products@intermotive.net  
NFPA501-A-02-INS

## Data Link Harness (6-pin connector)

- Locate the vehicle's OBDII Data Link Connector. It will be mounted below the lower left dash panel.
- Remove the mounting screws for the OBDII connector. Plug the red connector from the NFPA501-A Data Link Harness into the vehicle's OBDII connector. Ensure the connection is fully seated and secure with the supplied wire tie.
- Mount the black connector from the Data Link Harness in the former location of the vehicle's OBDII connector.
- Leave the 6-pin "Data Link" connector unplugged from the 6-pin connector on the NFPA501-A module.



## NFPA501-A Translator Connection Output

- The NFPA501-A Data Link Harness has a 4-Pin White connector that provides J1939 data for connecting to a VDR. The pinout is as follows:

Pin #1 Green Wire - J1939 CAN High. Pin #2 Red Wire - Battery Voltage.

Pin #3 Blue Wire - J1939 CAN Low. Pin #4 Gray Wire - Ground.

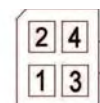

## VDR Installation

Install the VDR per manufacturer's instructions connecting the VDR J1939 signals to the 4 pin Data Link Harness connector. See pinout above. Use solder and heat shrink tubing to make these connections.

**Replacing the seatbelts** - Red extended length Crew cab seat belts are part of the NFPA501-A kit. These will be used to replace the OEM seat belts front and rear. No belt is provided for the front center seat. Refer to Ford OEM service manuals for replacement details.

- The front and rear seats will need to be removed. Disconnect the large connector under the drivers seat to allow removal. Note that this connects to an airbag and pyrotechnic device contained inside the drivers seat.
- When replacing the seat belts and buckles (OEM driver buckle is not replaced) observe proper Ford OEM torque specs summarized below. (Note: Per Ford Motor Co. front seat bolts must be replaced when removed).
- Remove all seat belts and replace with the provided red NFPA seat belts. Observe location labels on the red seat belts which indicate the proper locations.
- **Notes:**
  - The OEM driver's (left) buckle is NOT replaced, but is used by this system.
  - Do NOT replace the seats until all harnesses have been installed.
  - You can release the rear center seatbelt anchor by pushing in the latch using a straightened paper clip.

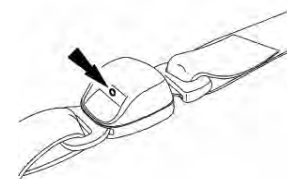

	Driver	Front Center Passenger	Front Passenger	Rear Left Passenger	Rear Center Passenger	Rear Right Passenger
Belt Assembly (all three bolts same)	40Nm (30ft-lbs)	Not supported	40Nm (30ft-lbs)	40Nm (30ft-lbs)	30Nm (22ft-lbs)	40Nm (30ft-lbs)
Buckle Assembly	Do NOT re-move	Not supported	35Nm (26ft-lbs)	40Nm (30ft-lbs)	40Nm (30ft-lbs)	40Nm (30ft-lbs)

InterMotive Inc.  
13395 New Airport Rd. Suite A  
Auburn, Ca. 95602

Phone: (530)-823-1048  
Fax: (530)-823-1516

www.intermotive.net  
products@intermotive.net  
NFPA501-A-02-INS

## Installing the Seat Occupant Sensors

### Front Seats

- Invert front seats to expose serpentine springs and foam.
- Remove springs from their retainers and lay forward (Figure 5a).
- Place the 8.0 inch by 5.5 inch seat sensor and protective plastic guard between the seat springs and foam, with the plastic guard against the springs. Position it forward so the long side of the sensor meets the front metal pan. Sensor wires should exit toward the rear of the seat.
- Place four cable ties through the plastic guard holes and secure to the springs.
- Do not install front seats at this time.

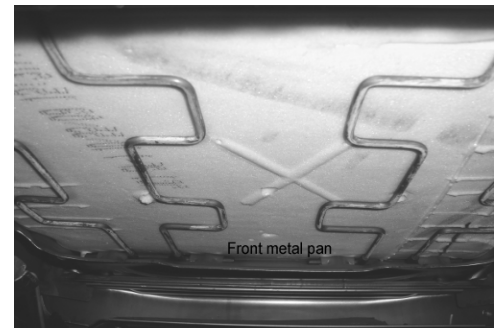

### Rear Seats

- Fold rear seat bases up.
- Open the rear seat upholstery hook and loop at back to expose metal pan and foam.
- Place the 8.0 inch by 3.0 inch seat sensor and protective plastic guard between foam and metal pan, with the plastic guard against the metal pan and the long side in line with seat, as indicated in (Figure 5B), for each of the 3 rear seat positions.
- Exit sensor wires toward the rear of the seat.
- Close and reattach upholstery.



### Sensor Harness Installation

- Remove the front left kick panel below the left A-pillar.
- Remove the drivers side front and rear (under door) scuff plates. Harnesses will be routed under these.
- Starting from the rear right seat position, lay the rear seat portion of the sensor harness along the back wall toward the left side of the vehicle so the connector pairs are centered at each seat position.
- Lay the rear seat assembly in place, and connect each rear seat sensor and seat buckle sensor to the harness.
- Open the left side plastic cable enclosure that resides under the scuff panel.
- Continue laying the sensor harness forward in the plastic cable enclosure to beyond the B-pillar.
- Feed the front seat portion of the sensor harness under the carpet just behind the front seats toward the right of the vehicle.

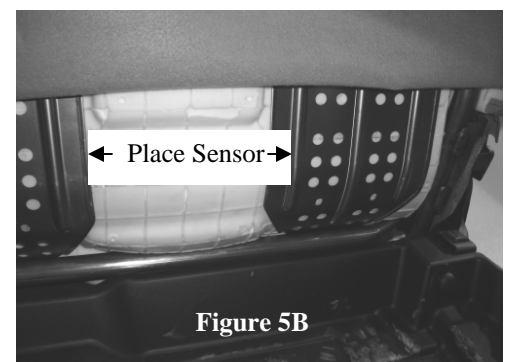

## Sensor Harness Installation Front Seats

- Feed the left front connector pair out of the carpet opening for the left floorboard vent under the driver seat.
- Locate the C311 connector. (34-pin connector under the Driver's seat)
- **Important:** On the following wires use solder and heat shrink tubing to make all of the connections.
- Cut the C311 Pin #11 Green/Blue wire 1" from the connector.
- Attach the C311 Pin #11 Green/Blue harness side wire to the Purple blunt cut wire of the NFPA501-A Sensor Harness.
- Attach the C311 Pin #11 Green/Blue connector side wire to the Lt. Brown blunt cut wire of the NFPA501-A Sensor Harness.
- Cut the C311 Pin #12 Black wire 1" from the connector.
- Attach the C311 Pin #12 Black harness side wire to the Black blunt cut wire of the NFPA501-A Sensor Harness.
- Attach the C311 Pin #12 Black connector side wire to the Gray blunt cut wire of the NFPA501-A Sensor Harness.
- Feed the right front connector pair out of the carpet opening for the right floorboard vent under the passenger seat.
- Connect the respective sensor connectors to the harness.
- Continue laying the sensor harness forward in the plastic cable enclosure to the A-pillar.
- Feed the sensor harness upward, either along the A-pillar or forward of the park brake, to the left side vent panel. (Figure 6, detail 2).
- If the park brake route is selected ensure the harness does not interfere or entangle in the park brake mechanism.
- Finish harness placement so the two end connectors are accessible at opening below the vent at the left side vent panel.
- Adjust the harness as necessary so the wires are not pulled too tight.
- Tuck the harness into the floor at the rear wall (behind the rear seat).
- Close the plastic enclosures under the scuff panels.
- Reinstall the front seats. Torque seat mounting bolts to 70Nm (52 ft-lbs).  
Note: Front seat bolts must be replaced when removed, per Ford Motor Co. Technical Information.
- Connect the front seat sensors and seat belt switches to the NFPA501-A Sensor Harness.
- Reconnect the C311 connector halves.
- Reinstall the front left kick plate. Reinstall scuff plates.

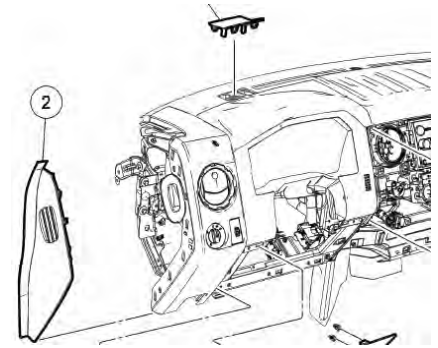
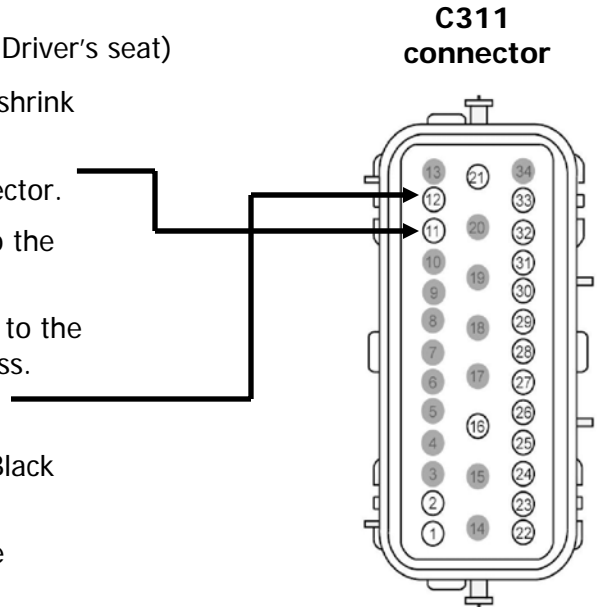

Figure #6

## Warning Beeper Installation

- Find an appropriate location for mounting the warning beeper. Some vehicles have a vertical bracket just in front of the 4WD floor shifter which works well as a mounting bracket. Attach the 4 Pin Warning Beeper harness to the NFPA501-A Module's 4-Pin white connector.
- Attach the 12-Pin connector Pin #12 Orange wire to the Positive side (red painted terminal) of the Warning Beeper.



## LED Display Panel Installation

- Some upfitters simply leave the display connected, but un-mounted to allow the final stage manufacturer and all optional equipment such as radio's are installed. Suggested locations include the dash board within view of the driver and the front passenger (captain position), which must be able to see the LED panel should a laptop or other additional equipment is place on or at the center console. A common location is the space below the left A/C vent. The length of the display harness is 40". This is the maximum distance the display can be mounted from the NFPA501-A module.
- Attach the 4 Pin LED display harness to the NFPA501-A Module's 4-Pin Black connector.
- Attach the other end of the display harness to the LED Display Panel.



## Sensor Harness Connection

- Connect the sensor harness 10 pin connector to the NFPA501-A module.
- Connect the sensor harness 12 pin connector to the NFPA501-A module.

## Reconnect the battery

### Initial Installation Power-Up from factory:

With the key ON and engine OFF, plug in the 6-pin Data Link harness connector to the white 6-pin connector on the NFPA501-A module. This "Hard Boot" will cause the module to go into a special "Install Routine". This routine runs functions that will assure the module is configured properly to the vehicle in which it is installed:

#### 1. CAN detect:

First, the module auto-detects the vehicle CAN communication network to verify it can read vehicle data. If the module fails to detect the CAN bus, **module LED6 will turn ON and LEDs 1-4 will scroll**. In addition, the far right 2 sets of LEDs (top & bottom row) on the external display will be "rotating". The module will not function if this happens.

The most likely problem in this case is something wrong with either the vehicle OBDII connection or in the harness connecting to the module.

## Initial Installation Power-Up (Continued)

### 2. Seat Selection:

The module will try to establish which seat positions are active in the vehicle. It does this by reading seat belt sensors. The driver's seat is always enabled, but all other positions (4) can be set active or inactive to allow for custom configurations. If inactive, they will neither be displayed nor reported (to the VDR). In order for a specific position to be sensed and therefore deemed "active", it needs a proper harness connection to the module, and additionally the seat belt must be unbuckled. **Make sure all positions that need to be active are set up this way prior to running the install routine.** If there is ever a need to disable one or more seat positions, all that is needed is to plug in the belt of the seat to be deactivated prior to running the install routine. Having no buckle connection to the harness will give the same result.

Once the seat selection is complete, the module will "flash out" the seat configuration using module LEDs 1-5. The LEDs will blink several times indicating (by being ON) which positions are active. Seats are represented as follows:

LED1—Driver	LED3—Rear Left	LED5—Rear Right
LED2—Front Right	LED4—Rear Middle	

As stated above, the seat selection routine runs automatically the first time (from the factory) power is applied to the module. If seat selection is ever needed at a later time, a "special hard boot" needs to be run. To do this, make and hold a ground connection to the module test pad while plugging it in with the key on. The module will "see" this and run the seat selection routine.

If seat selection fails, **module LED7 will turn ON and LEDs 1-4 will scroll.** If you see this indication, the problem is most likely the module itself. Contact Intermotive Technical Support 530-823-1048.

### 3. VIN Capture:

The first time (from the factory) the module is plugged in, it will try to read the vehicle VIN. It needs this to assure that vehicle data will be correctly received and interpreted. If it cannot acquire the VIN or if the acquired VIN is invalid, the module yellow Status LED will flash, and the external display LEDs will "dance". If VIN acquisition was successful, the module stores and uses it for future reference. If VIN cannot be acquired, the module will not function; contact Intermotive Technical Support 530-823-1048.

## Post Installation Test

With vehicle in Park, Parking Brake applied, and Key OFF (module asleep):

- Turn Key ON. Verify all Display Panel LEDs come on together briefly (prove out).
- Sit in each seat location, and verify respective red LED illuminates on the panel.
- While sitting in the seat, buckle the seat belt, and verify red LED goes out and the green LED illuminates.

While sitting in a seat (seat belt unbuckled, vehicle in Park, and Park Brake applied):

- Move transmission selector out of Park position, and verify audible beeper activates.
- Press Silence button (on Display Panel), and verify beeper stops. Shift back into Park position.
- Leave the seat for 3 sec, then sit back down again. This resets the alarm function.
- Release park brake, and verify audible beeper activates.
- Buckle seatbelt, and verify the beeper stops. Turn key off.

If the system fails any step in the Post Installation Test, review the installation instructions and check all connections. If necessary, call

**InterMotive technical support @ (530) 823-1048**

Yellow Status LED



## NFPA/Seat Belt Monitor NFPA501-A

2011 Ford F250-550 Series Crew Cab 6.2L, 6.7L, 6.8L

### Operating Instructions (leave in vehicle)

The NFPA501-A system monitors up to five seats in a crew cab vehicle to ensure the occupants have their seat belts properly buckled. It flashes a red indicator identifying seat positions which are not buckled, and sounds a warning beeper. It requires the seat to be occupied *before* the belt is buckled to discourage spoofing the system. It also translates and sends vehicle chassis data, along with seat belt data to an optional Vehicle Data Recorder.

#### Operational Notes:

- When the key is turned on, all Display Panel LEDs will blink on briefly as a test.
- Sitting in each seat location will illuminate the respective **Red** LED on the panel.
- When sitting in an unbelted seat, moving the transmission selector out of the Park position will sound the beeper.
- Also when sitting in an unbelted seat, releasing the park brake will sound the beeper.
- Inserting the seatbelt into the buckle while sitting in each seat will illuminate the respective **Green** LED and the extinguish the respective **Red** LED.
- Inserting the seatbelt into the buckle without sitting in the seat will flash the respective **Red** LED.
- Removing the buckle from the seatbelt of the unoccupied seat will stop the beeper.
- Pressing the Silence button anytime the beeper is sounding will stop the beeper for that seat only.

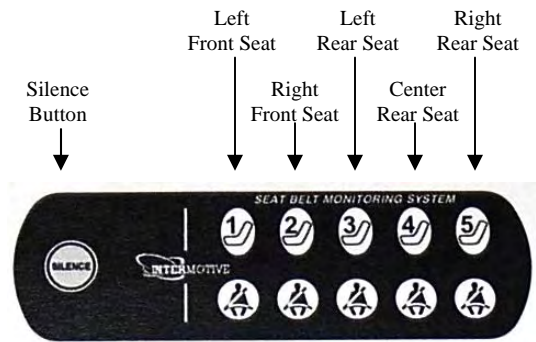

For technical support, call **InterMotive @ (530) 823-1048**.

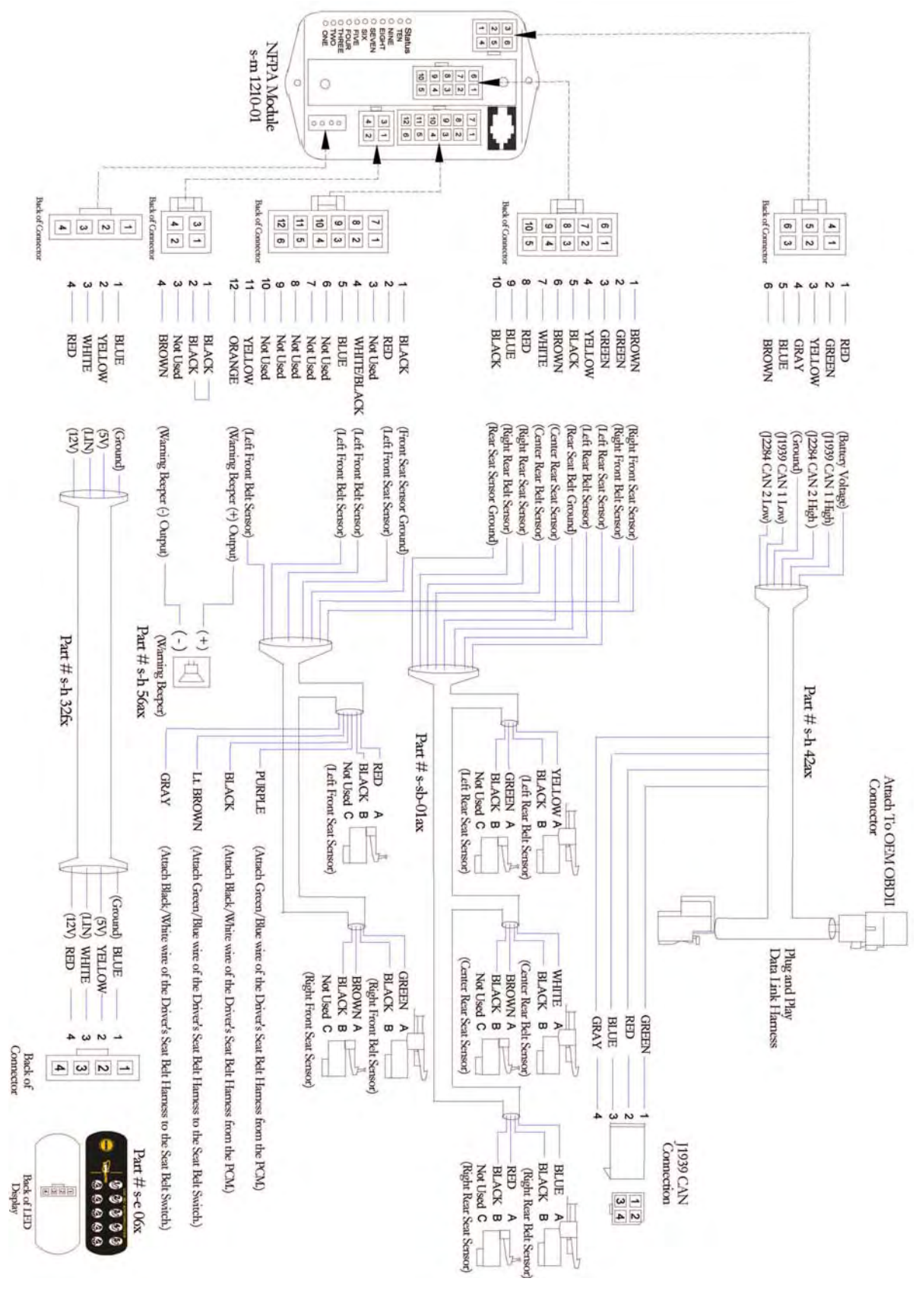

Submit product registration at [www.intermotive.net](http://www.intermotive.net)  
 If the NFPA 501-A fails any step in the System Operation Test, review the installation instructions and check all connections.  
 If necessary, call

InterMotive technical support @ (530) 823-1048. NFPA501-A-02-CAD